

IP67 LED Underground Light

Installation Step

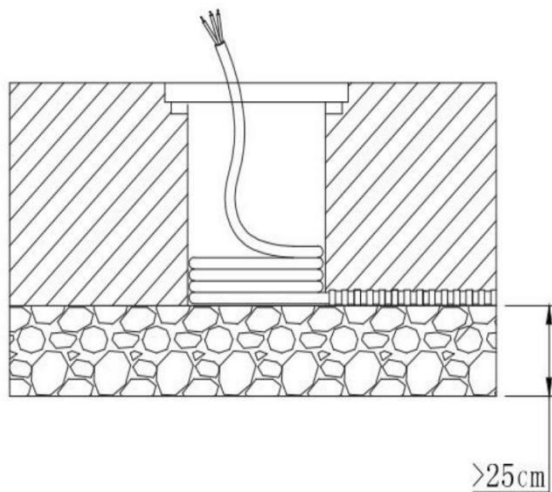

Step 1: Install the sleeves into the ground, the top side should on same level with the ground surface. cable need go through the sleeve.

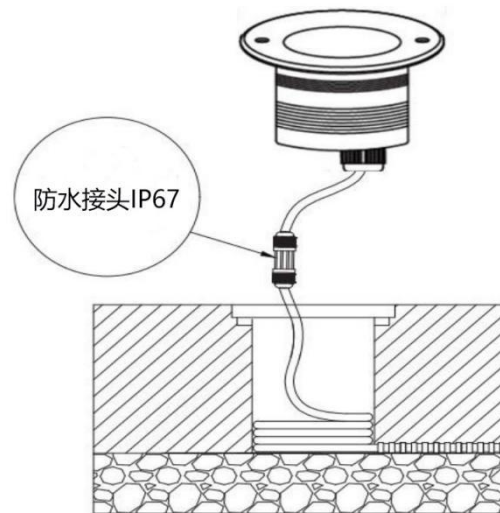

Step 2: Connect the cable with the light. Keep enough length for maintain.

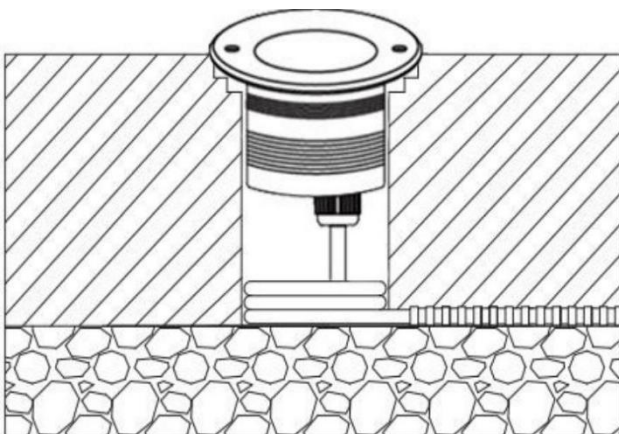

Step 3: Put the light fixture into the sleeve

*The thickness of the gravel must ticker than 25cm.

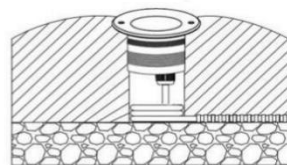
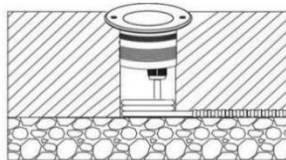
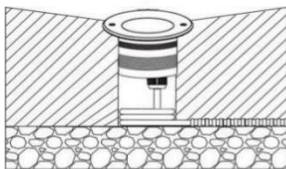

NOTE:

1. Use correct voltage ;
2. Cut off the power before maintenance;
3. Please don't disassemble the lamp fitting at will, or it won't be waterproof;
4. Cable inter face must reaches IP67 or higher;
5. Please don't install the lamp in low-lying area where water is easy to accumulate.

IP67 Led Underground Light

Connection: (High Voltage AC100-240V)

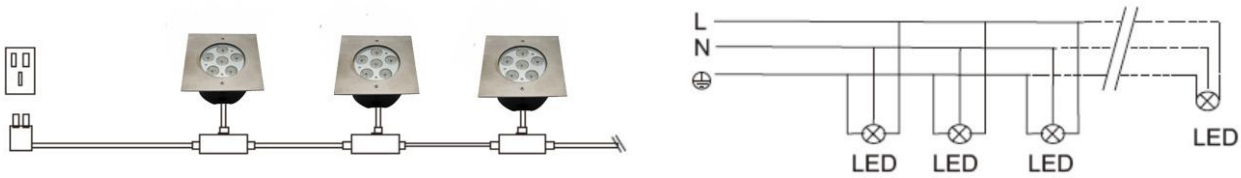

(Low voltage DC24)

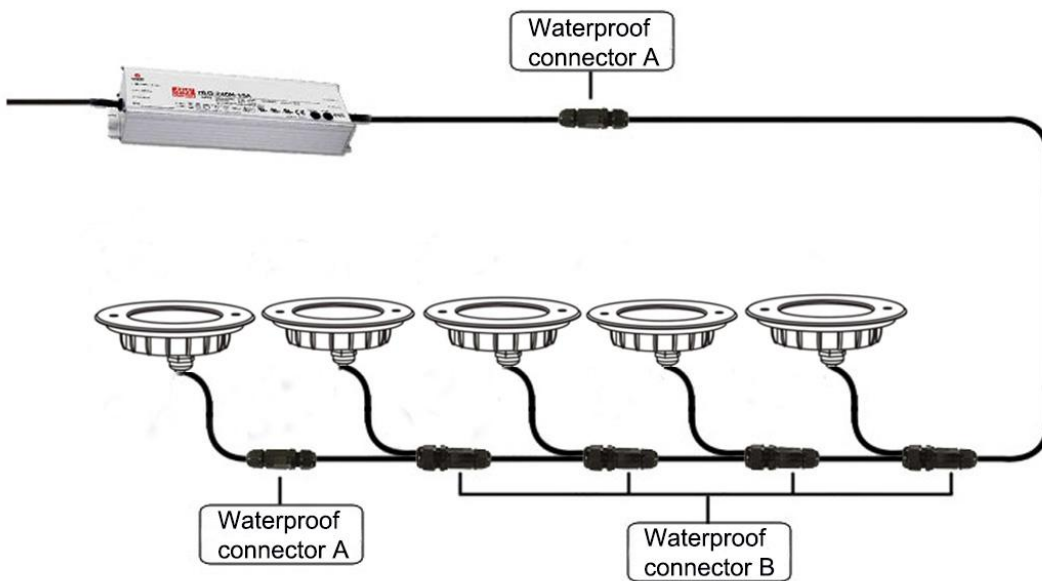

Waterproof treatment (don't put joint part in water)



***It is recommended to use IP67 waterproof connector for the cable interface, please make sure that the thread is tightened to prevent water entering the connector due to misoperation.

Caution:

1. Only professional people to make installation, please check the fixture well before installation;
2. Please install the lights according to this data sheet carefully, screw the light well and connect the wire correctly.

Warning:

- * Neglect on action of the above treatment will lead to failure of waterproof and proper working of the lights!!
- * Make sure the ground connection well avoid electric shock, due to metal housing.

Note: The above instruction are subject to update or improved without notice.
Please turn to our staff for further details ! Thanks for your long term support!